

Development, Design, Manufacturing, and Testing of a Production Green Chile De-Stemming Machine

Ryan Herbon, P.E.
M-TEC Engineer



9/13/2010

©2010 New Mexico State University



M-TEC / NMCA Partnership

- M-TEC is the Extension Engineering Program in NMSU's College of Engineering
- M-TEC Provides Technical Assistance, Workforce Development Training and K-12 Outreach to the State of New Mexico
- M-TEC has partnered with the New Mexico Chile Industry over the last 10 years to develop several pieces of machinery for the mechanization of the chile crop in NM
- The New Mexico Chile Association funds projects through M-TEC to help the Industry



NEW MEXICO CHILE ASSOCIATION

Need for a De-stemmer

- The NMCA identified the de-stemming of peppers as a critical need for the industry
- Currently 100% of the Green Chile and Cayenne Peppers grown in New Mexico are hand harvested due to the need to remove the stems at harvest
- No machine is commercially available to de-stem the pods
- Commercial machines are available to harvest the product (designed for red chile)



Computer Controlled Cutter

- After several years of prototyping different machines, a decision was made to move forward with a Computer Controlled Cutter to allow for precise de-stemming of chile peppers
- Shape and size of chile is irrelevant to operation of machine
- Requires relatively complex computer control system.
- A 10 lane, 10,000 lb/hour machine has been designed and built

2010 Design

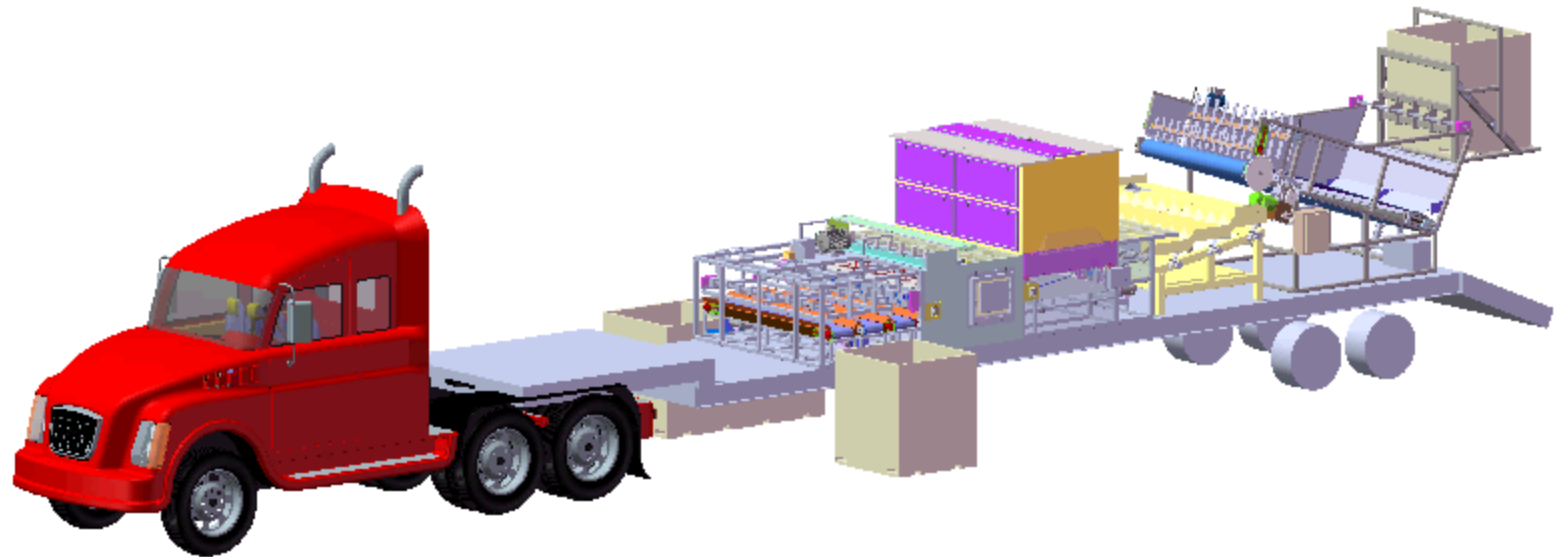

2010 Design

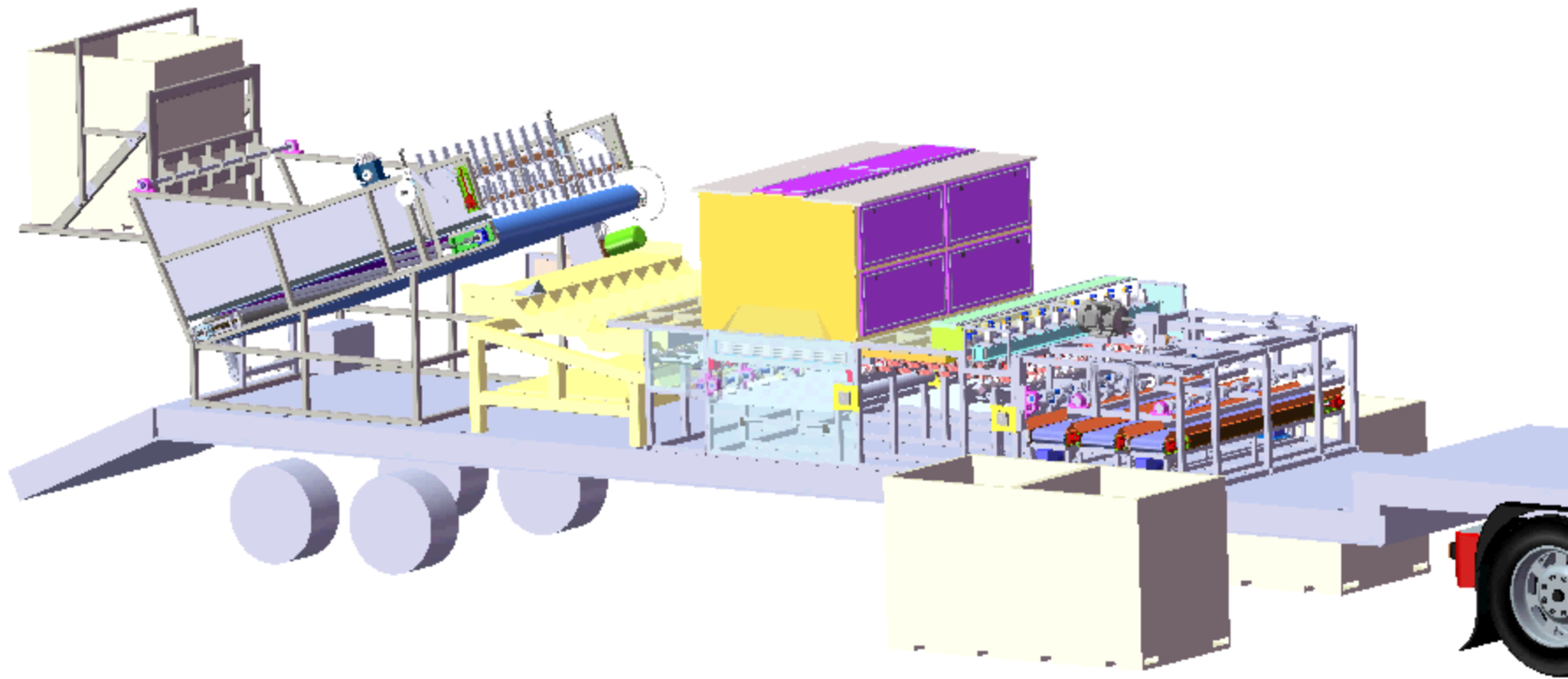

2010 Design

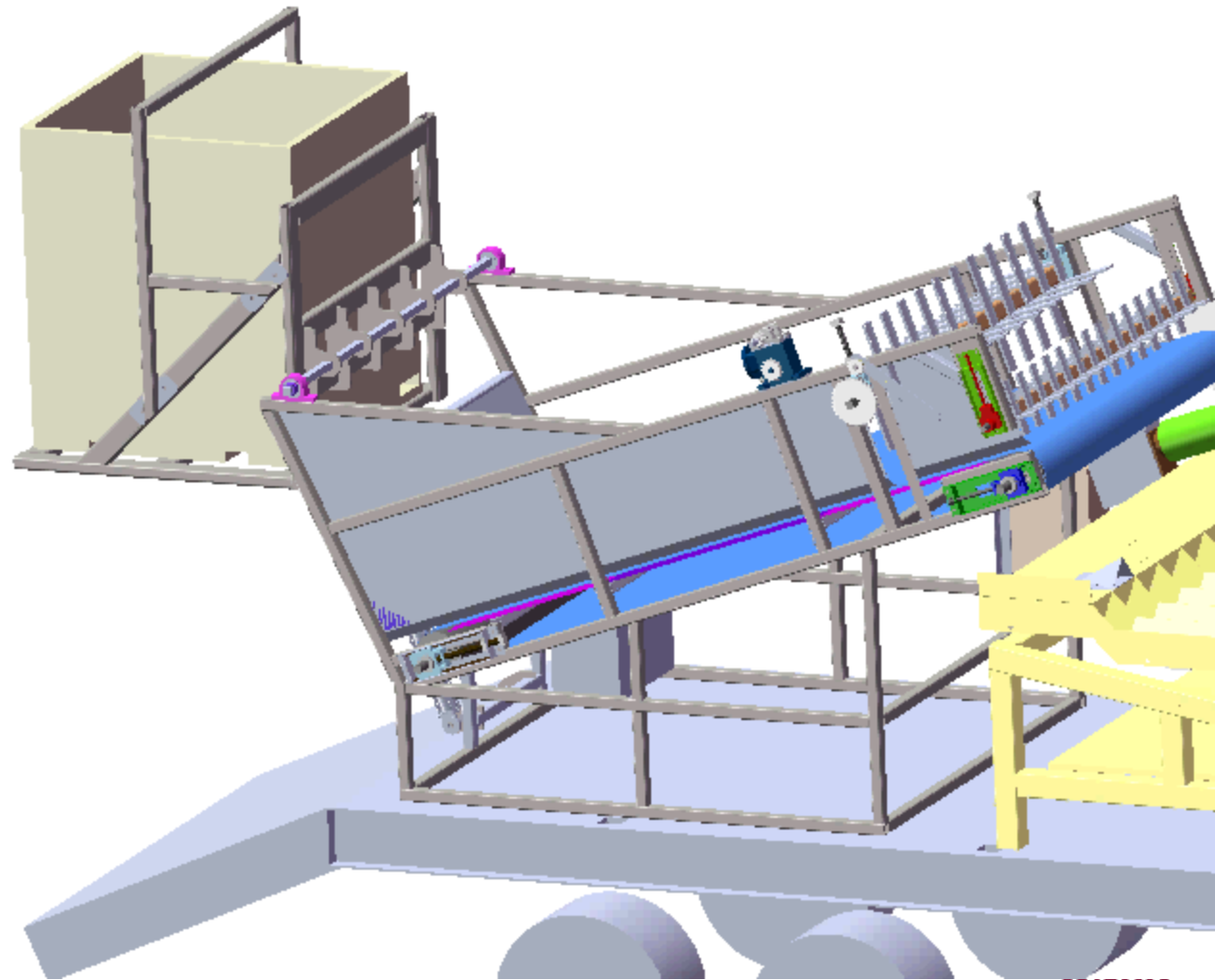

2010 Design

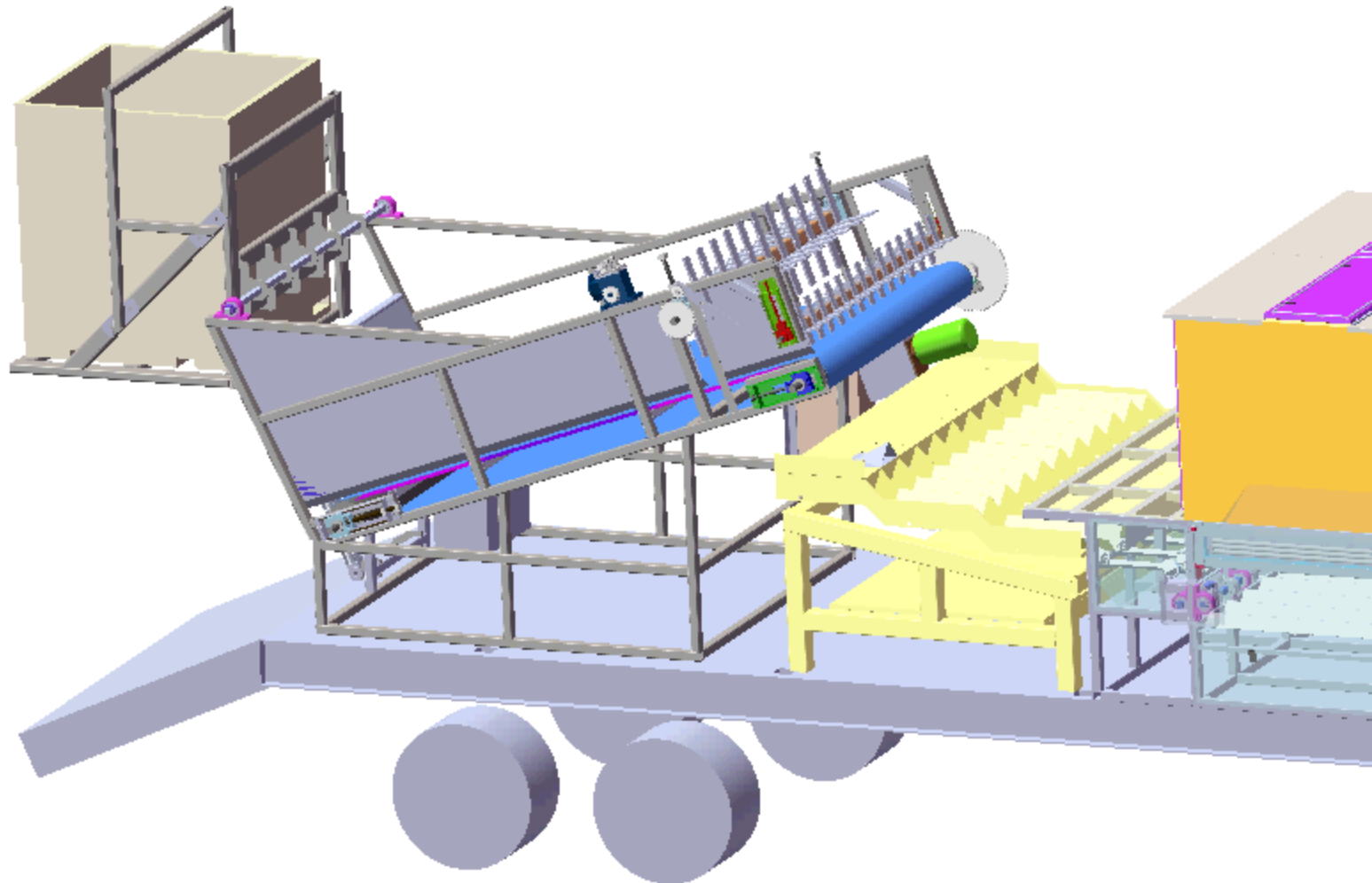

2010 Design

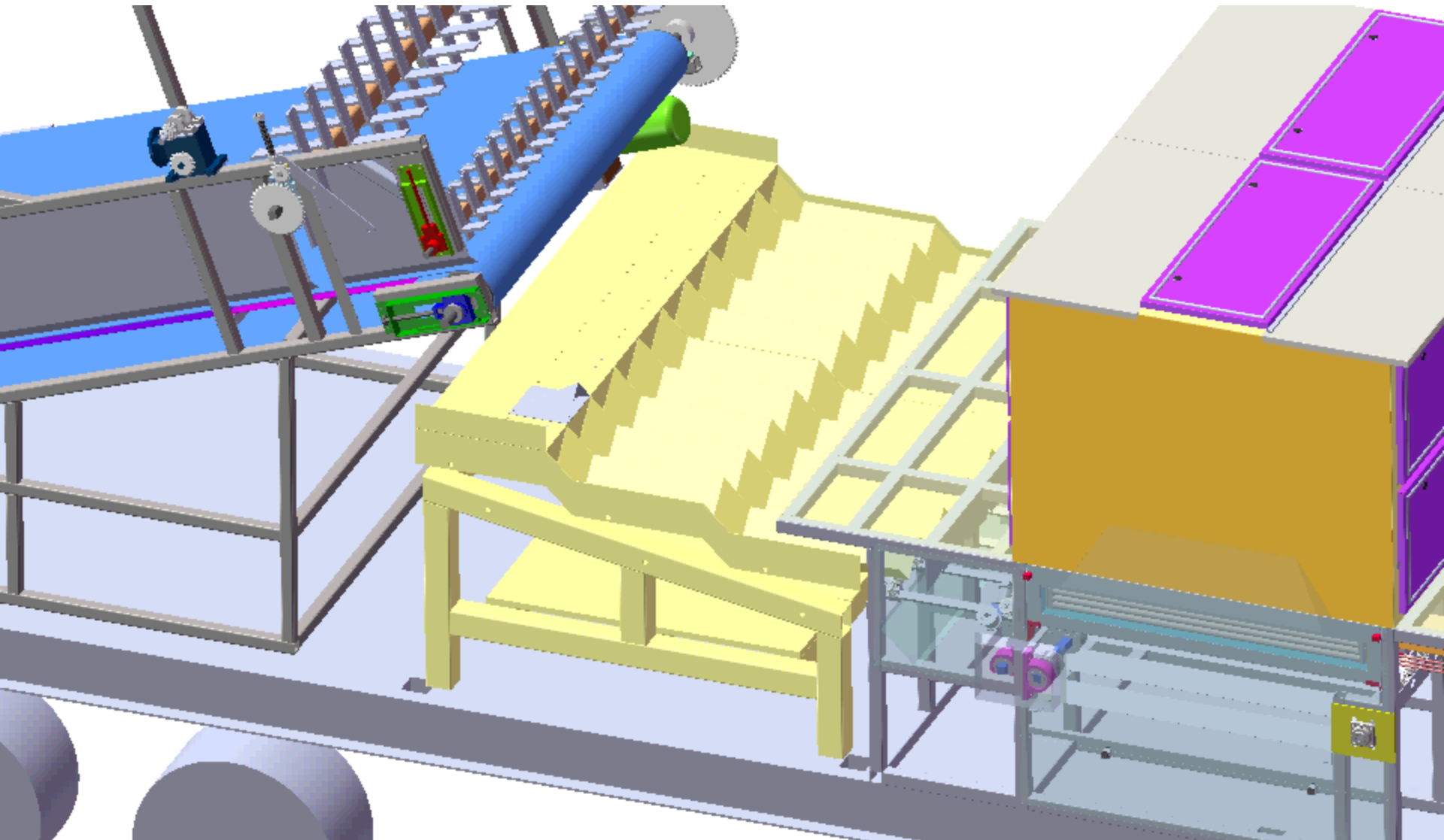

2010 Design

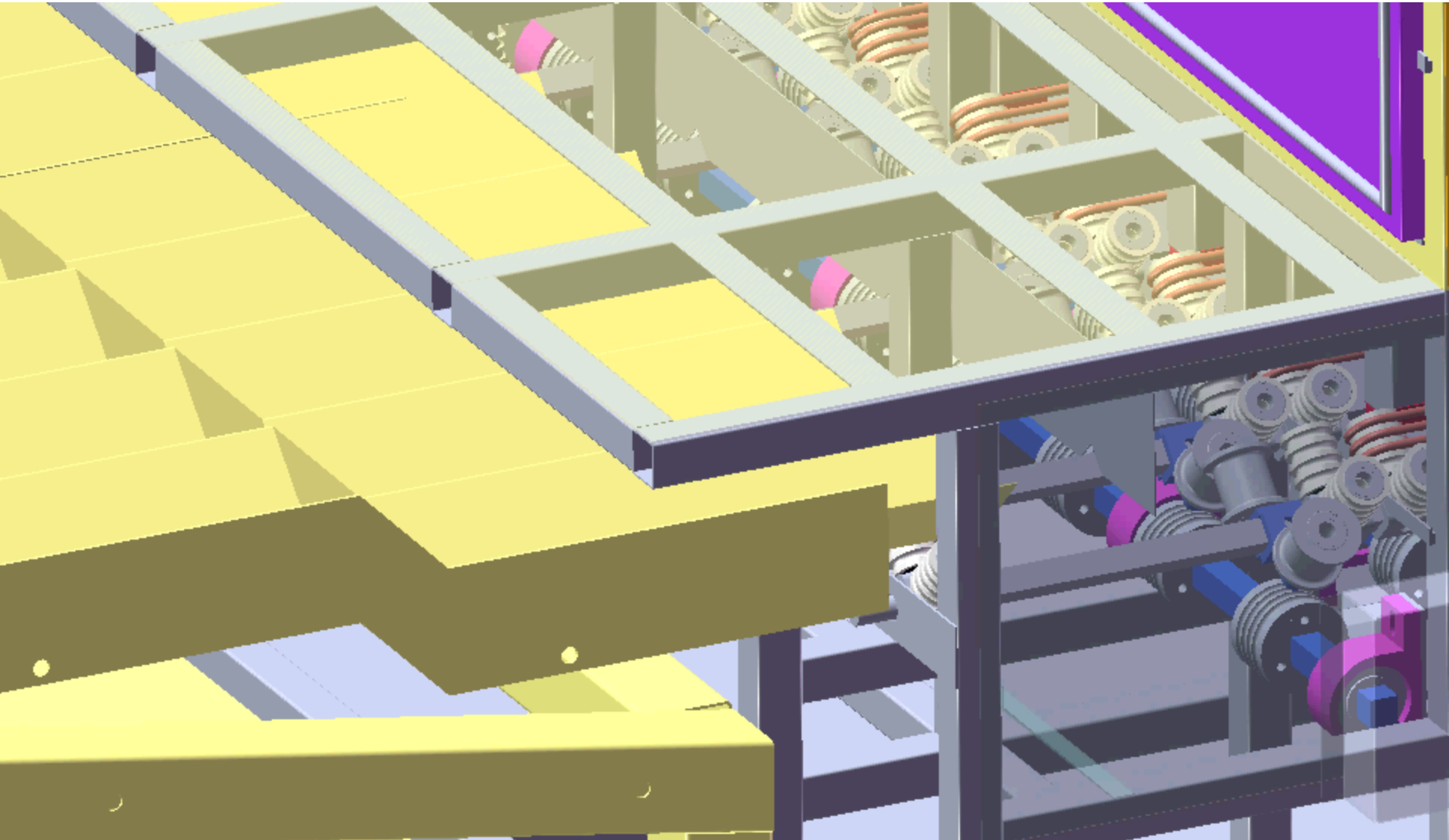

2010 Design

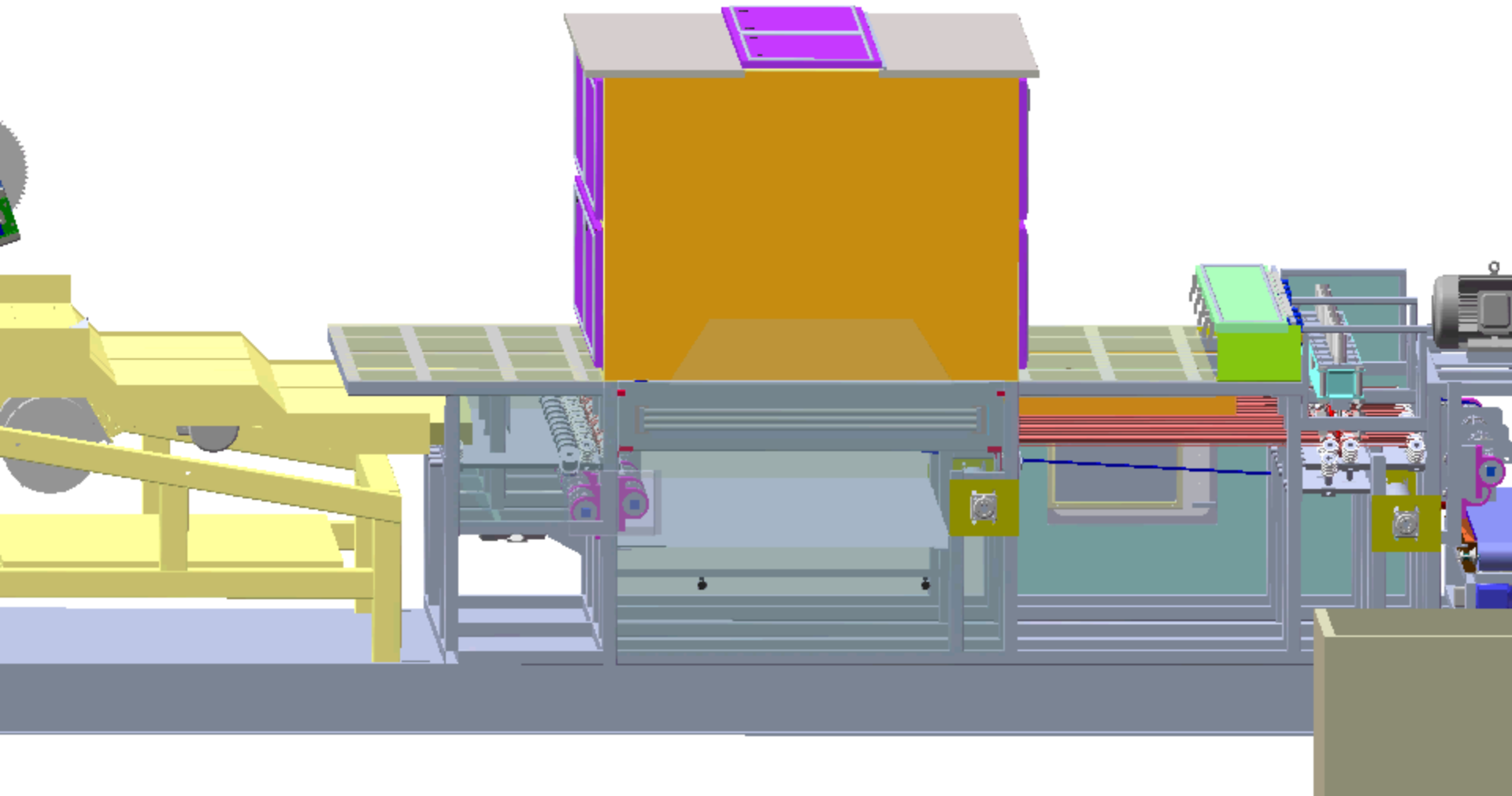

2010 Design

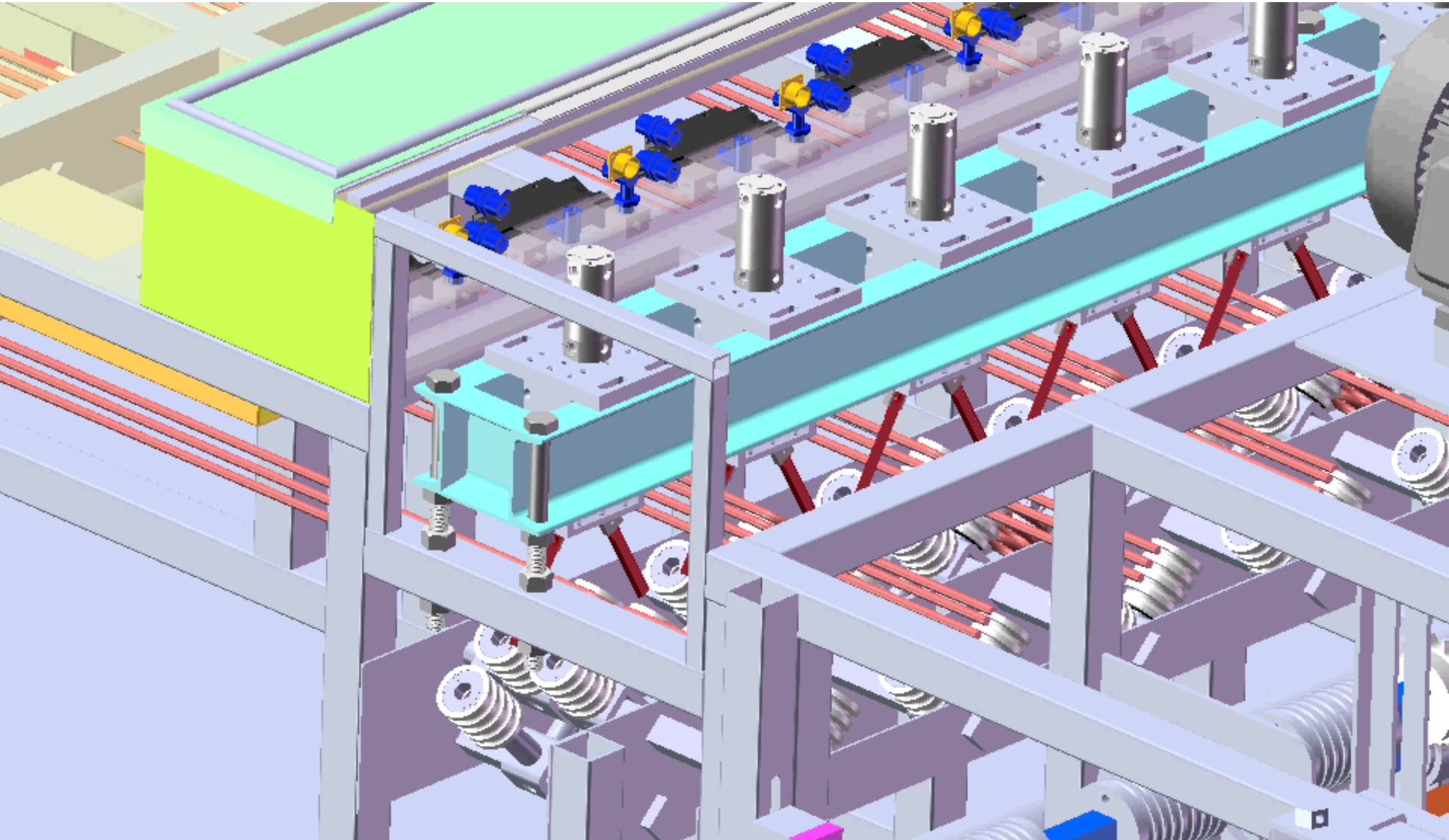

Control System

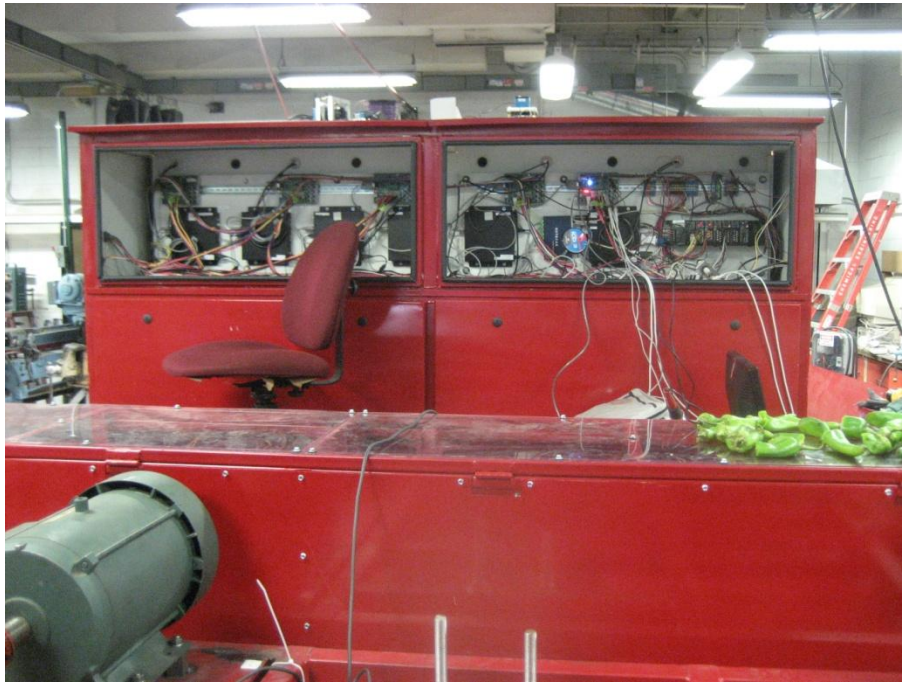

- The control system on the machine consists of:
 - 6 Windows based computers
 - 5 Custom Printed Circuit Boards
 - 1 Programmable Logic Controller

Image Acquisition

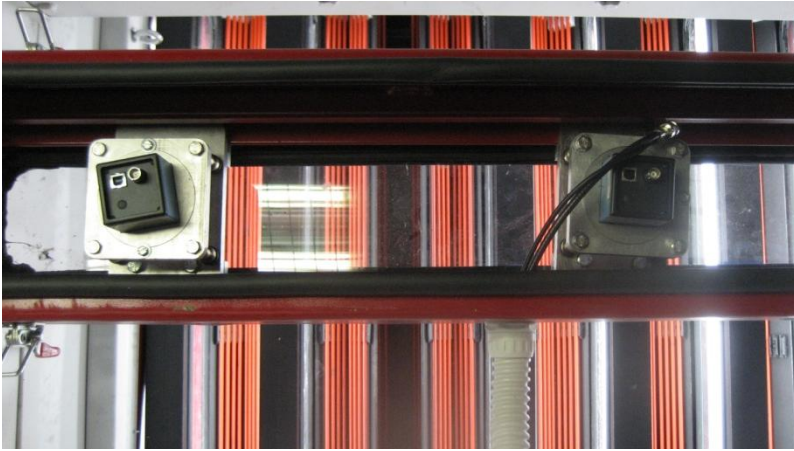

- The computer captures an image of the belt and determines the cut locations

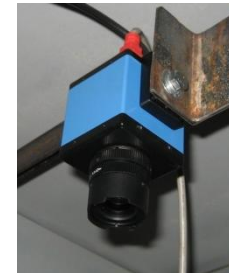
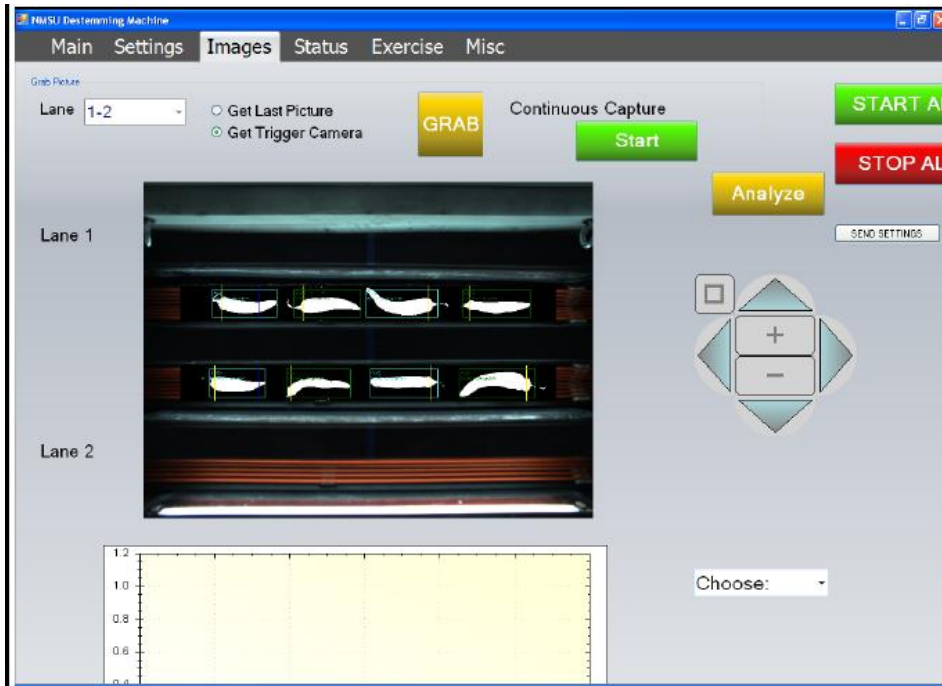
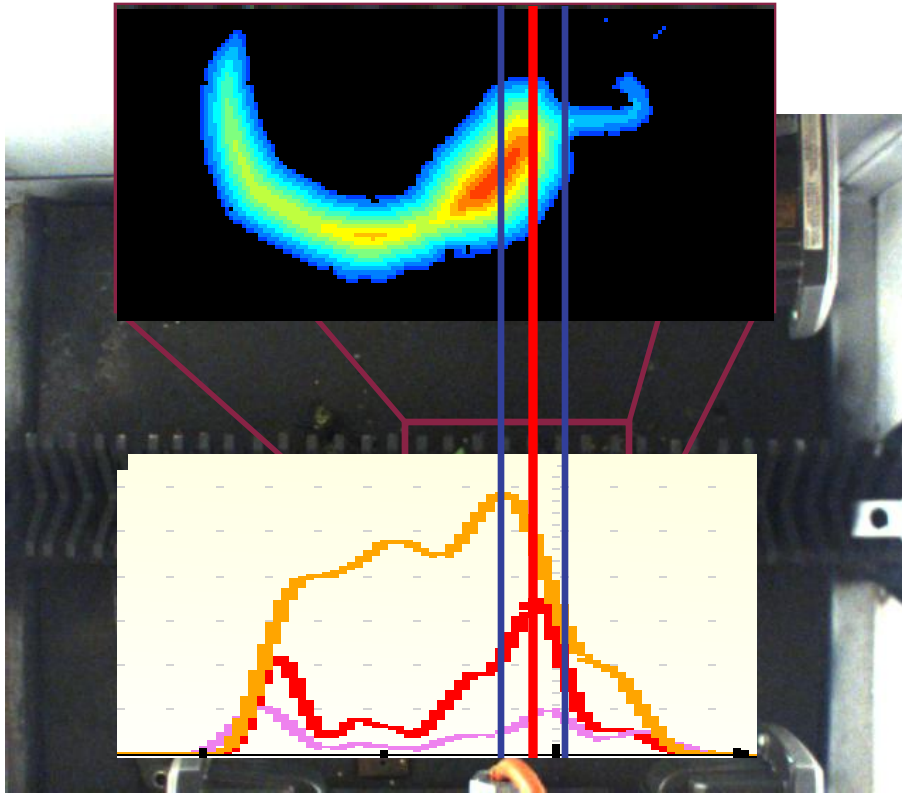

Image Acquisition



- An image is captured every 40 inches of the belt and then processed
- The entire 40 inches is scanned for pods and cut locations
- Allows up to 0.500 seconds to process the image before a new image must be captured

Image Processing Calculations



- Acquire the image
- Threshold the image based on Hue, Saturation and Luminance
- Run a “distance from edge” function on each white pixel
- Identify the max distance in each column
- Get the gradient of the max distance graph
- Multiply the two together
- Identify the max of the result graph as the cut location
- Cut can then be adjusted either into or out of the pod

Cut Head

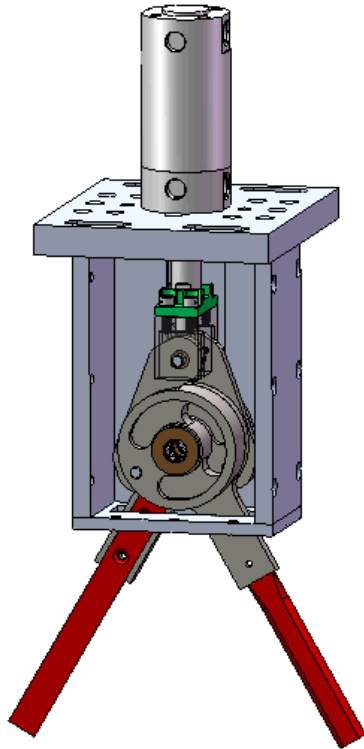

- Scissor mechanism cuts the stems off with two crank-slider mechanisms
- Actuated by pneumatic cylinder
- Operates 1 cut/stroke in 11 ms

Manufacture



- The machine was manufactured over a 4 month period in the summer of 2010
- M-TEC devoted 6 Engineers, 2 shop managers and 10 students full time to the project

Testing



- The machine has been undergoing preliminary in-house testing at M-TEC's shop
- It is planned to run the machine at Bueno Foods in Albuquerque and Border Foods in Deming over the next month
- Two of the ten lanes are currently operational for initial testing

NMSU De-Stemmer

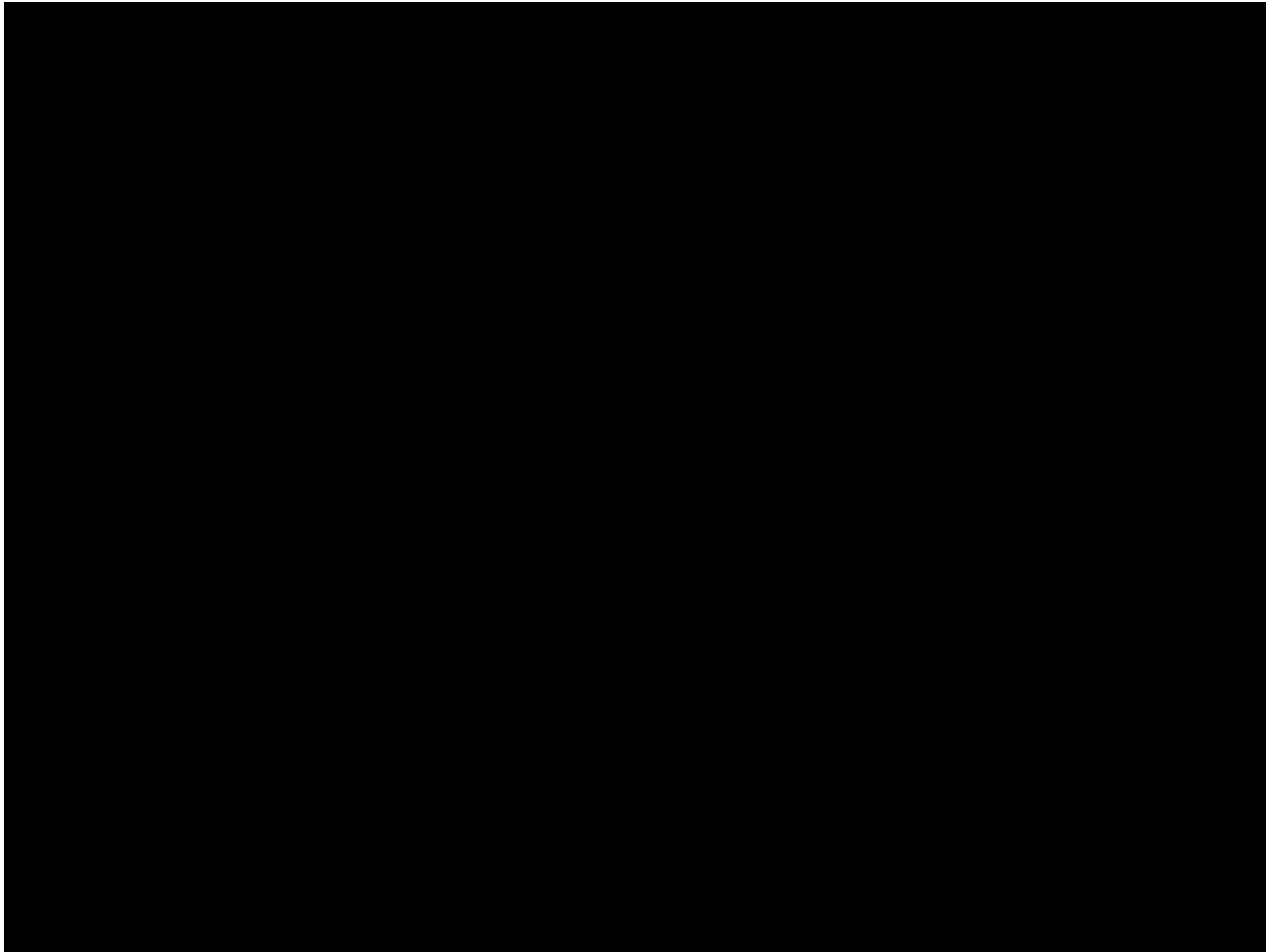

Questions

